

TEAM DURANGO DEX410/R SETUP SHEET

PRINT

SUBMIT

NAME / NOM: Joe Nolasco - www.RPPHOBBY.com - www.TEAMRPP.com

DATE / DATUM: 9-12-2010

SETUP BLATT / FICHE DE RÉGLAGE **V1.0 E**

EVENT / VERANSTALTUNG: Club Race

TRACK / STRECKE: J&S Raceway, Lakeport, CA

AIR TEMP / UMGEBUNGSTEMP: 85 ° F

TRACK SIZE / STRECKENLÄNGE: 100'x60'

SURFACE / STRECKENBELAG: Clay

TRACTION LEVEL / GRIFF: High

CONDITIONS / WETTER: Damp

DEX410 DEX410R

RIDE HEIGHT
BODENFREIHEIT GARDE AU SOL
16 mm

CAMBER ANGLE
STURZ ANGLE DE CARROSSAGE
2 °

CASTOR ANGLE
NACHLAUF ANGLE DE CHASSE
STK °

TOE IN / OUT
VONSPUR/NACHSPUR ANGLE DE PINCEMENT
+/- 1 deg. in °

DIFF. OIL
DIFF. ÖL HUILE DE DIFF.
7k Mugen .wt

SWAY BAR
STABILISATOR BARRE ANTI-ROULIS
no mm

SWAY BAR LINK
STABILISATOR HEBELANGE LIEN DE LA BARRE ANTI-ROULIS
mm

NOTES
NOTIZEN REMARQUES

FRONT VORN AVANT

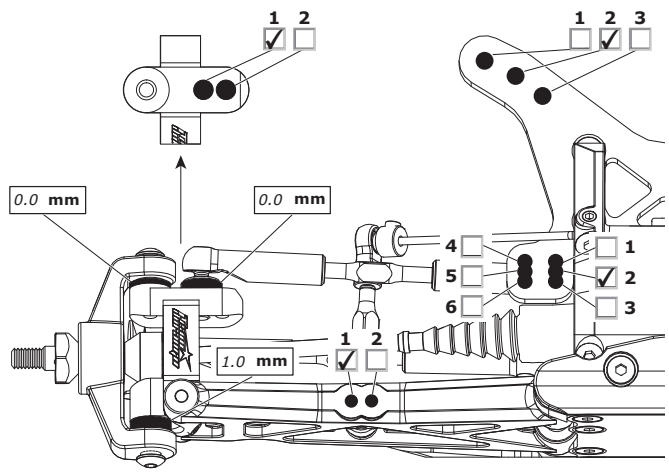

RIDE HEIGHT
BODENFREIHEIT GARDE AU SOL
16 mm

CAMBER ANGLE
STURZ ANGLE DE CORROSSAGE
2 °

DIFF. OIL
DIFF. ÖL HUILE DE DIFF.
20K Durango Diff Grease .wt

SWAY BAR
STABILISATOR BARRE ANTI-ROULIS
no mm

SWAY BAR LINK
STABILISATOR HEBELANGE LIEN DE LA BARRE ANTI-ROULIS
mm

WISHBONE DROOP
AUSFEDERIG AXSE DROOP DES TRIANGLES ARRIÈRES
FULL mm

NOTES
NOTIZEN REMARQUES
1 Deg. Rear Hubs

REAR HINTEN ARRIÈRE

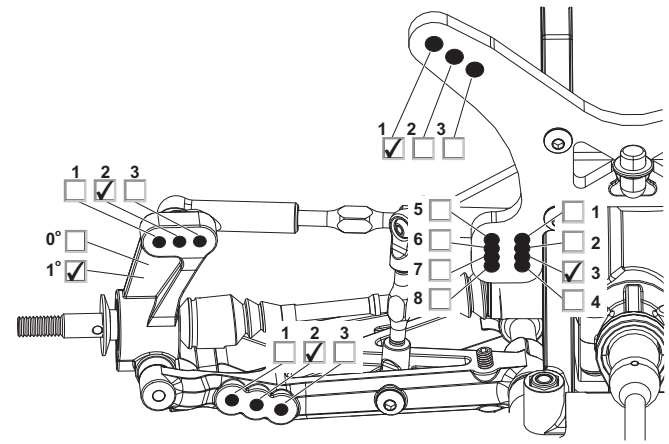

MOTOR MOTOR MOTEUR
LRP Vector X12 7.5

SPUR GEAR
HAUPTZÄHNRAD COURONNE
STK

PINION GEAR
RITZEL PIGNON
22

BATTERY
AKKU ACCUMULATEUR
Racer's Edge 5200 45C

ESC SETTINGS
REGLER PROGRAMM RÉGLAGE DU VARIATEUR
STK

BALLAST POSITION
GEWICHTSPOSITION POSITION DES LEST
 SIDES A

SKIDPLATE B

WING
FLÜGEL TYPE D'AILERON
STK

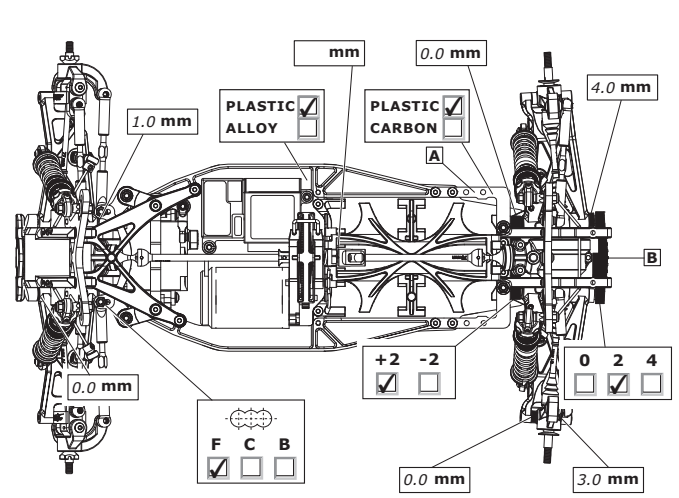

FRONT SHOCKS VORNE DÄMPFER AVANT AMORTISSEURS

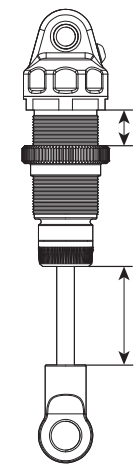

SPRINGS
FEDERN RESSORTS
Dark Blue 3.64lb/in

REBOUND
REBOUND REBOUND
0 %

PRELOAD
FEDERVORSPANNUNG PRÉCONTRAINTÉ
8 mm

OIL WT.
ÖLVISKOSITÄT GRADE HUILE
Losi 27.5 cST

PISTON
KOLBEN PISTON
2 hole drilled to 1.35mm

LENGTH
LÄNGE LONGUEUR
mm

NOTES
NOTIZEN REMARQUES

REAR SHOCKS HINTEN DÄMPFER ARRIÈRE AMORTISSEURS

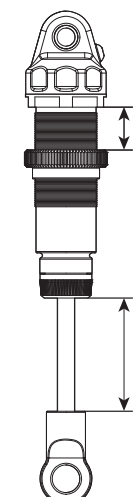

SPRINGS
FEDERN RESSORTS
Light Blue 1.85lb/in

REBOUND
REBOUND REBOUND
0 %

PRELOAD
FEDERVORSPANNUNG PRÉCONTRAINTÉ
8 mm

OIL WT.
ÖLVISKOSITÄT GRADE HUILE
Losi 22.5 cST

PISTON
KOLBEN PISTON
3 Hole

LENGTH
LÄNGE LONGUEUR
mm

NOTES
NOTIZEN REMARQUES

TYRES REIFEN PNEUS

FRONT | **REAR**
BRAND HERSTELLER MARQUE
Hole Shot 2.0 | Hole Shot 2.0

COMPOUND MISCHUNG COMPOUND
M3 | M3

INSERT EINLAGEN INSERT
STK | STK

WHEEL FELGE JANTE
Durango | Durango

NOTES NOTIZEN REMARQUES

Alteration: Arn0 at petitrc dot com



www.team-durango.com © Team Durango Ltd. 2010

RESULTS PLATZIERUNG RÉSULTAT QUALIFYING POSITION / VORLAUFERGEBNIS POSITION EN QUALIFICATION: 1 FINAL POSITION / ENDPLATZIERUNG POSITION FINALE: 1

AVERAGE LAP DURCHSCHNITTSZEIT TEMPS AU TOUR MOYEN: 22.890 **BEST LAP** SCHNELLSTE RÜNDE MEILLEUR TEMPS AU TOUR: 22.890 **RACE TIME** RENIDAUER DURÉE DE LA COURSE: 7 Mins.